



The New Piper Aircraft, Inc.
 2926 Piper Drive
 Vero Beach, Florida, U.S.A. 32960

SERVICE No. 1123B BULLETIN

**PIPER CONSIDERS
 COMPLIANCE MANDATORY**

Date: April 20, 2006 (M)

SB 1123A Service Bulletin superseded SB 413 and SB 1123 in their entirety. SB 1123B adds instructions for PA-34-200 aircraft, S/N 34-7250001 thru 34-7350135 without "Upstop" kit 760-699 installed and revises effectivities for the PA-34-220T Seneca V aircraft.

**SUBJECT: PA-34 SERIES AIRCRAFT NOSE GEAR
 INSPECTION AND PRODUCT IMPROVEMENTS**

<u>MODELS AFFECTED:</u>	<u>SERIAL NUMBERS AFFECTED:</u>
PA-34-200 Seneca	34-7250001 through 34-7450220
PA-34-200T Seneca II	34-7570001 through 34-8170092
PA-34-220T Seneca III	34-8133001 through 34-8633031; 3433001 through 3433172 and 3448001 through 3448037
PA-34-220T Seneca IV	3448038 through 3448079 & 3447001 through 3447029
PA-34-220T Seneca V	3449001 through 3449261; 3449263 through 3449312

NOTE: The instructions contained in this Service Bulletin are in effect until the contents are incorporated into the appropriate Seneca Maintenance Manual, at which time this Service Bulletin becomes obsolete.

COMPLIANCE TIME: To coincide with the next regularly scheduled maintenance event, but not to exceed fifty (50) hours time in service or unless otherwise specified in the "Instructions" section of this service bulletin.

APPROVAL: The technical content of this Service Bulletin has been shown to comply with the applicable Federal Aviation Regulations and is FAA approved.

PURPOSE: A review of the service difficulty reports concerning PA-34 Nose Landing Gear indicates a need to emphasize and expand upon the periodic inspection requirements currently listed in the PA-34 series Maintenance Manuals in order to avoid the possibility of nose gear failures and inadvertent retractions. A design review of the installation has resulted in the modification of some of the components to extend their long-term service life. This publication introduces the revised inspection requirements and identifies those parts which have undergone design modification improvements. Included are revisions and refinements of the rigging procedures pertaining to the Nose Gear installation.

INSTRUCTIONS:

1. Inspections

The following Table 1 lists scheduled maintenance actions and inspections pertaining to the Nose Landing Gear that will be included in all PA-34 series Maintenance Manuals. These Inspections are in effect until the contents of this service bulletin are incorporated into the appropriate Maintenance Manuals. All other Landing Gear inspections as called out in the "Scheduled Maintenance" section of the appropriate Aircraft Maintenance Manuals are still valid and must be complied with in addition to these inspections.

(OVER)

ATA: 3220

Nature of Inspection	Inspection Time (hrs)			
	50	100	500	1000
1. Inspect nose gear steering control and travel. (Refer to the "Alignment of Nose Gear" section of the applicable Maintenance Manual.		0	0	0
2. Inspect gear struts, attachments, torque links, retraction links, bolts and bushings for condition and security. (Refer to the "Cleaning, Inspection, and Repair" section of the applicable Maintenance Manual). See section 3 of this service bulletin for wear limits.		0	0	0
3. Visually inspect (2000 hrs. initial) the nose gear trunnion (P/N 95723-00, -05, -06) for cracks in the area of attachment to the nose gear mount assembly (See Figure 1) using supplemental lighting and a 10X magnifier				0
4. Inspect nose gear upper drag link AN7-35 attach bolt or the (alternate NAS6207-50D bolt (Ref. Instruction Step 2. a. in this Service Bulletin). Replace the drag link bolt AN7-35 or NAS6207-50D every 500 hours.		0	0	0
5. Inspect the nose gear retraction link retention spring (P/N 96178-0) for damage, distortion, or corrosion.		0	0	0
6. Remove triangular shaped, nose gear strut servicing access panel located in the forward baggage compartment. a. Inspect nose tiller roller, steering arm channel and tiller track for condition. b. Examine the tiller, tiller roller, and steering arm channel, turn-stop bosses for damage caused by exceeding nose wheel turn limits when towing with power equipment. c. Inspect the AN4-10A bolts attaching the P/N 95393-00 arm to the steering channel for proper torque (50-70 in. lbs). If found loose, replace bolts and re-torque.		0	0	0
7. Inspect the nose gear drag link center pivot and attachment bolts for condition and security. (Replace as required.)		0	0	0
8. Inspect the nose gear down lock link assembly for binding, worn spring retention pin, and any noticeable elongation of the hole associated with the spring retention pin. Inspect the down lock link spring for damage, distortion, or corrosion. Clean and lubricate the link using MIL-L-7870 oil.		0	0	0
9. Inspect the actuator mounting bracket for cracks, elongation of the .250 dia. holes where the retraction link attaches, and for loose mounting rivets. (Reference Figure 1A for rivet inspection details) See paragraph 2. c. for aluminum -vs- steel mounting bracket inspections. See section 3 of this service bulletin for wear limits. See applicable S/N below. a. 34-7250001 through 34-7570050 b. 34-7570051 and Up For aircraft in category 9.a. that have had the steel mount bracket installed (95724-004 thru -007, as applicable), inspection requirements shall be per category 9.b.	0	0 0	0 0	0 0
10. Inspect the bolt and bushing associated with the attachment of the P/N 95712-00 or -04 retraction link to the actuator mounting bracket. Replace if "wear grooves" are noted in either the bolt or bushing.		0	0	0
11. Inspect the AN23-25 stop bolt that is installed in the actuator mounting bracket for condition and security.		0	0	0
12. Lubricate the nose landing gear per the lubrication chart located in the applicable aircraft Maintenance Manual.	0	0	0	0
13. Verify proper adjustment of the nose gear down lock link by performing the rigging procedure per the "Installation and Rigging of the Nose Gear" section of the applicable Maintenance Manual, as modified by section 4, Rigging Instructions, of this service bulletin.				0

Table 1
Scheduled Maintenance

<p>14. Inspect the Tunnel Bracket 95554-000 installation for loose attachment rivets to the tunnel and nose gear mount fitting 95555-000 and visually inspect for cracks in the bracket attachment flange adjacent to the fitting. This inspection can be accomplished through an access opening located in the bottom skin at B.L. 00.00, just aft of Sta. 49.5 bulkhead. Inspect for loose rivets by observing the area during the landing gear cycle test performed per Inspection No. 9. (Ref Figure 1A) and looking for any relative motion between riveted components.</p>		0	0	0
--	--	---	---	---

Table 1 (Continued)
 Scheduled Maintenance

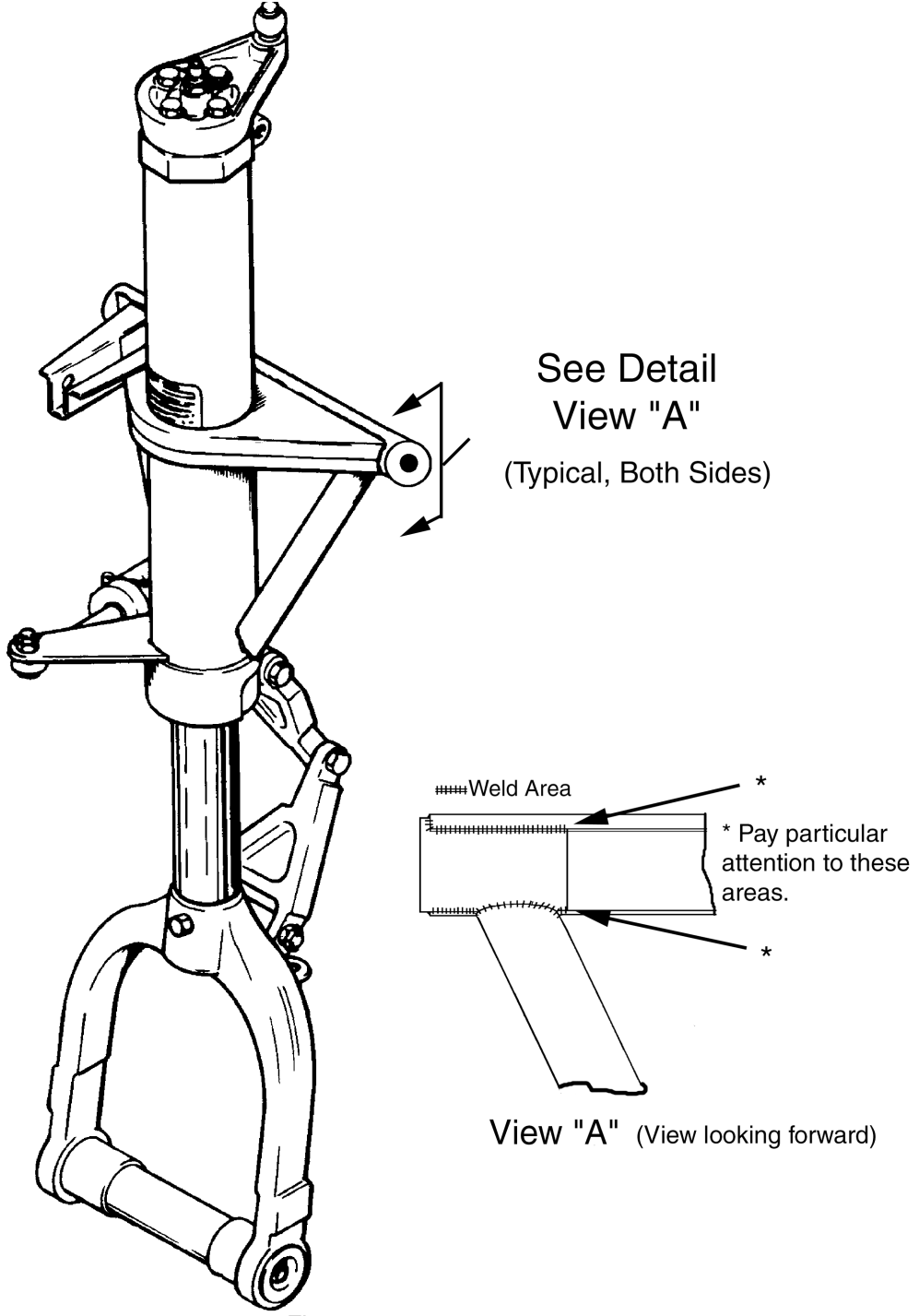
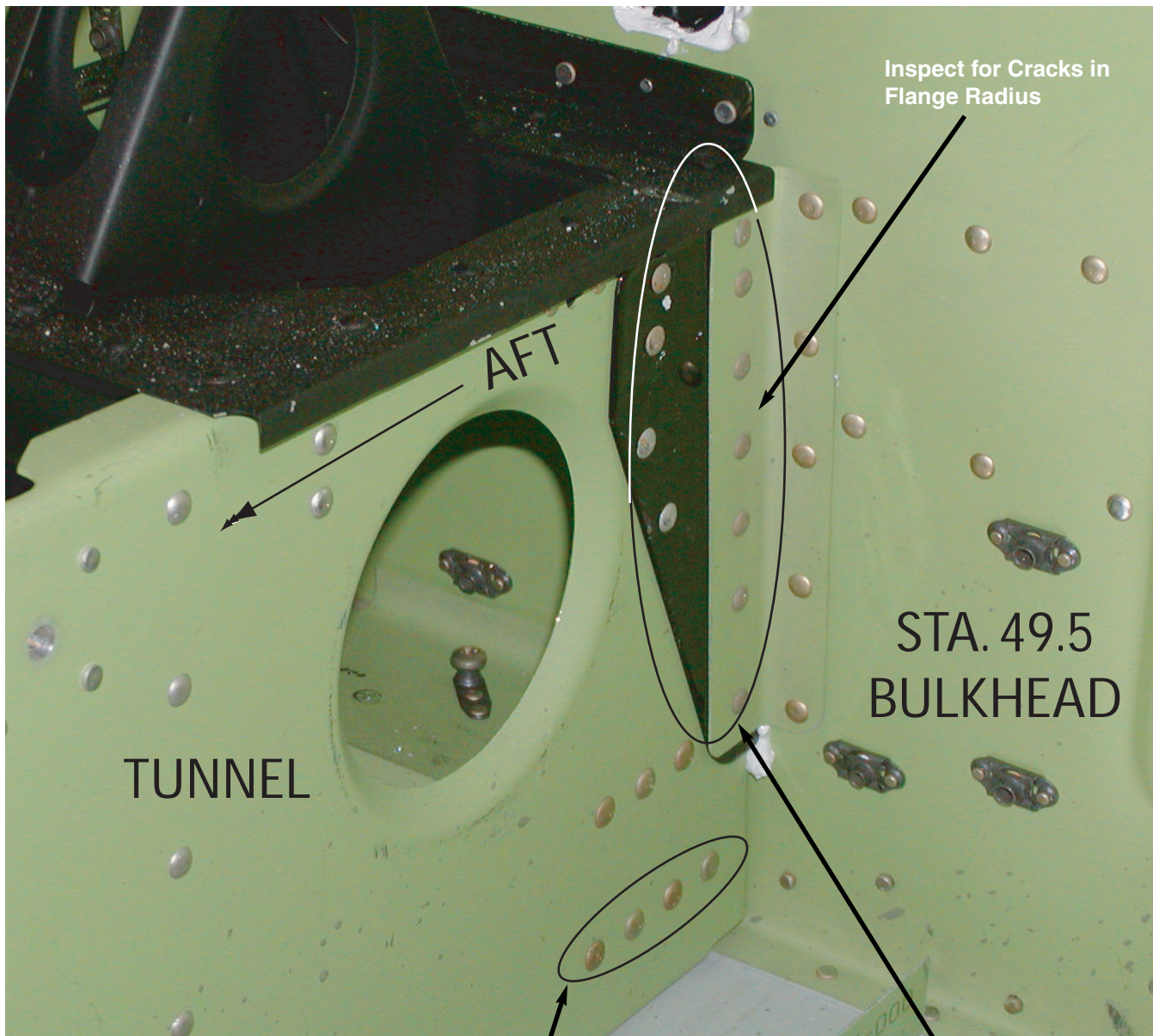

Figure 1
 Trunnion Inspection
 (See Table 1, Item 3)



Inspect These (4 Rivets) for Attachment of Tunnel Bracket 95554-000.

Inspect These 11 Rivets

Inspect for loose mounting rivets that attach the actuator mounting bracket to tunnel aft of Sta. 49.5 bulkhead by placing aircraft on jacks, extend and retract landing gear and note any relative motion between the subject bracket and the tunnel. It will be necessary to pull carpet away from the side of tunnel to inspect noted rivets.

Figure 1A
Actuator Mounting Bracket Rivets

INSTRUCTIONS: (Continued)

2. Modified Components

The following parts have been modified to increase their service life. This Service Bulletin does not require the immediate replacement of the currently installed part, but are recommended as replacements.

NOTE: Aircraft serial numbers 3449262, 3449313 and up have had these parts factory installed during production.

- a. Drag link-to-nose gear strut bolt, P/N 400-274 (AN7-35).

The Nose Gear Installation has been revised to change this AN7-35 bolt to P/N 693-215, (NAS6207-50D) bolt that is stronger. This bolt change is **approved** for all PA-34 Series aircraft, and is an Alternate Method of Compliance as a substitute for the P/N 400-274 (AN7-35) bolt per AD 93-24-14.

- b. Steering Channel Assembly 95394-000.

The Steering Channel has been revised to increase the material thickness by 25% and the height increased to prevent “ball-out-of-track” failures. The part number for the redesigned Steering Channel is 95394-005. The 95394-005 Steering Channel is Approved for all PA-34 Series aircraft.

- c. Actuator Mount Bracket P/N 95724 and Bushing P/N 95061-89.

The Actuator Mount Bracket has gone through two major design changes, from aluminum to steel, and a recent change of adding reinforcements to increase the bearing surfaces for the P/N 95061-089 bushing.

For all PA-34-200 and PA-34-200T serial numbers 34-7250001 through 34-7570050 (with aluminum bracket), visually inspect the **aluminum mount bracket** for wear, cracks, loose rivets and other damage, within the next **50** hours and at **50** hour intervals thereafter (Ref. Table 1, item 9).

For PA-34-200T aircraft, serial number 34-7570051 and up, for all PA-34-220T aircraft through serial number 3449193, visually inspect the **steel mount bracket** for wear, cracks, loose rivets and elongation of the attachment hole for the P/N 95061-089 bushing, within the next **50** hours and at **100** hour intervals thereafter.

The following kits are required if the aluminum or steel Actuator Mount Brackets are discrepant and must be replaced for the noted aircraft and serial numbers. The kit includes the latest design mount bracket and new required hardware for the attachment of the Nose Gear retraction Link Assembly P/N 95712-00/-04.

KIT NUMBER	MODEL	EFFECTIVITY	MOUNT ASSEMBLY
767-357	PA-34-200	34-7250001 thru 34-7350135	95724-007 Replaces 95724-000
767-358	PA-34-200	34-7350136 & Up	95724-005 Replaces 95724-002
767-358	PA-34-200T	34-7570001 & Up	
767-359	PA-34-220T III	34-8133001 & Up 3433001 & Up 3448001 thru 3448037	95724-006 Replaces 95724-004
767-359	PA-34-220T IV	3447001 & Up 3448038 & Up	
767-359	PA-34-220T V	3449001 through 3449261; 3449263 through 3449312	

Table 2
Actuator Mount Bracket Kits

- d. Turn-stop boss failure on the strut upper tube assembly P/N 95720.

Service Kit 767-368 has been established to add a Turn Limit Indicator on PA-34 Series aircraft prior to serial number 3449060. (PA-34-220T Seneca V aircraft serial numbers 3449060 & up have a factory installed turn limit placard.)

INSTRUCTIONS: (Continued)

3. Service Wear Limits

These Wear Limits are in effect until the contents of this service bulletin are incorporated into the appropriate Maintenance Manuals.

Table 3 is a "Wear Limits Chart" that can be used to determine the acceptable /or replacement condition for the listed parts that were inspected per Instructions Step 1. in this Service Bulletin. Visually inspect all bolts/pins for wear, damage, or corrosion. Replace as required.

Part Description		ID Wear Limits		Part Description		ID Wear Limits	
		Min.	Max.			Min.	Max.
1.	Drag Link Upper Bushing	0.562	0.564	6.	Steering Arm Center Pivot Sleeve	0.250	0.253
2.	Drag Link Center Bushing	0.375	0.377	7.	Down Lock Link Bushing	0.251	0.253
3.	Drag Link Lower Bushing	0.438	0.442	8.	Actuator Mount Bracket	0.250	0.252
4.	Trunnion Pivot Bushings	0.500	0.503	9.	Down Lock Link Rod End	0.190	0.192
5.	Steering Arm Center Pivot Bushings	0.375	0.377				

Table 3
Service Wear Limits

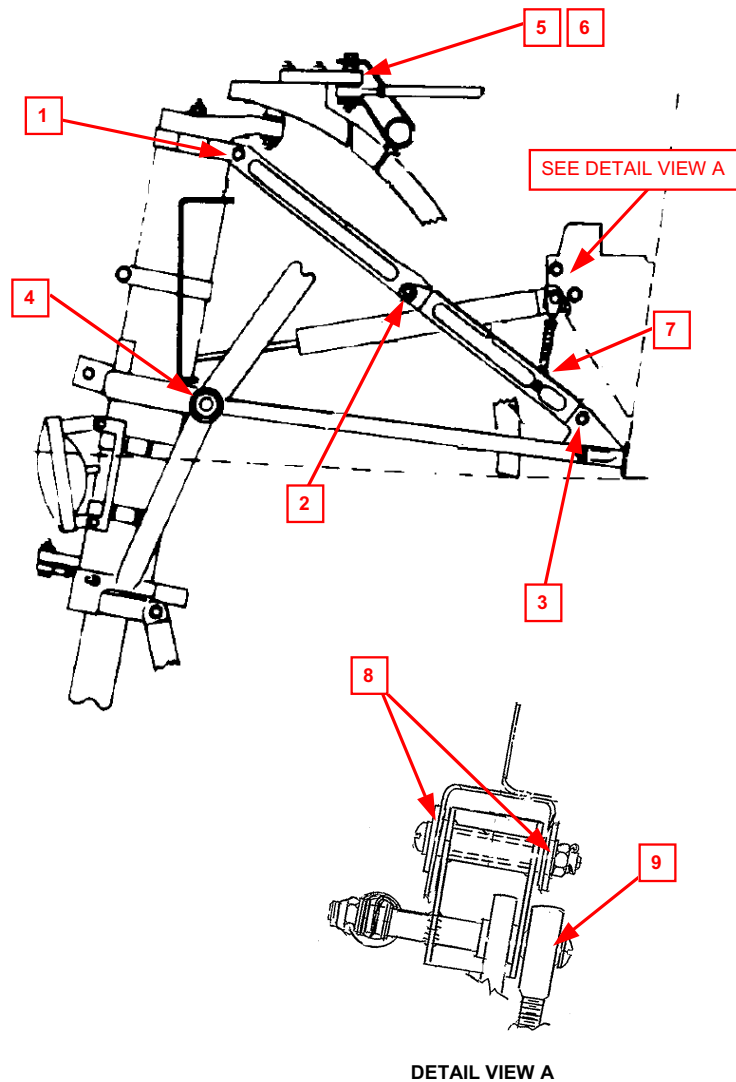

Figure 2
Service Wear Limit Locations

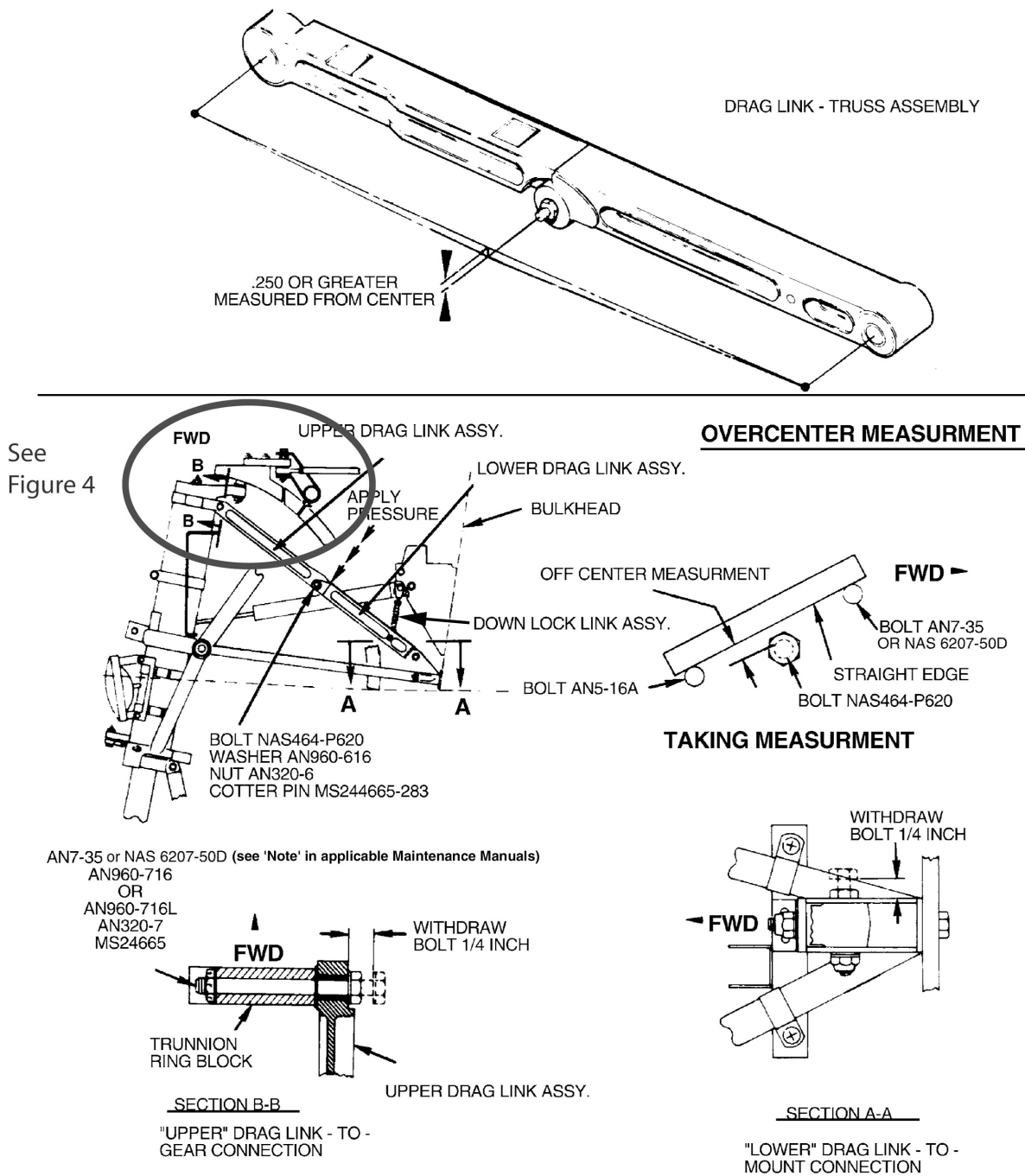
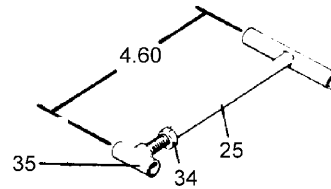

Figure 3
Drag Link Over-Center Measurement
Nose Gear Installation

1. BUNGEE ASSEMBLY
2. BOOTS
3. DOWNLOCK LINK ASSEMBLY
4. ACTUATOR
5. TILLER TRACK
6. UP LIMIT SWITCH
7. GEAR MOUNT
8. LOWER DRAG LINK
9. UPPER DRAG LINK
10. SPLASH SHIELD PANEL
11. TRUNION ASSEMBLY
12. UPPER TORQUE LINK
13. PISTON TUBE, STRUT ASSEMBLY
14. LOWER TORQUE LINK
15. FORK, STRUT ASSEMBLY
16. GEAR DOORS
17. GREASE FITTING
18. PUSH RODS, DOOR ACTUATING
19. TRUNION ARM, SHIMMY DAMPER ATTACHMENT
20. SHIMMY DAMPER SPRING ASSEMBLY
21. ROLLER
22. SPRING, DOWN RETURN
23. BOLT, WASHERS (4 OR AS REQ.), NUT
24. GEAR DOOR DRIVE ASSEMBLY
25. DOOR ACTUATING STOP ASSEMBLY
26. GEAR DOOR ACTUATING ASSEMBLY
27. SPLASH SHIELD MOUNTING CLAMP
28. GREASE FITTING
29. HARDWARE, TILLER / OLEO ATTACHMENT
30. TILLER ASSEMBLY
31. CHANNEL, STEERING ARM
32. STEERING ARM ASSEMBLY
33. STEERING ROD (2)
34. JAM NUT
35. ACTUATING LINK
36. MOUNT, ACTUATOR DOWNLOCK MECHANISM
37. RETRACTION LINK
38. SPRING, DOWNLOCK LINK
39. DOWNLOCK MICRO SWITCH
40. SPRING, RETRACTION LINK RETENTION
41. RUBBER STOP, GEAR UP STOP
42. SUPPORT TUBE, UP STOP
43. BOSS, STOP FITTING
44. JAM NUT

SKETCH A

1952
A332



SKETCH B

1952
A332

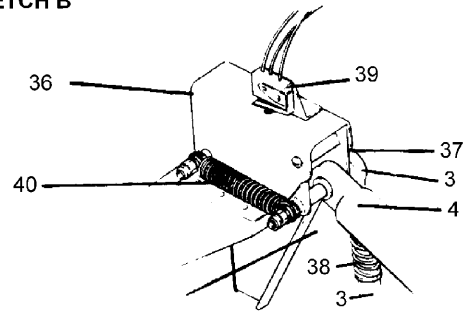

SKETCH C

1952
A332

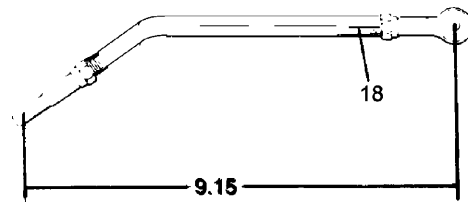

SKETCH D

C122

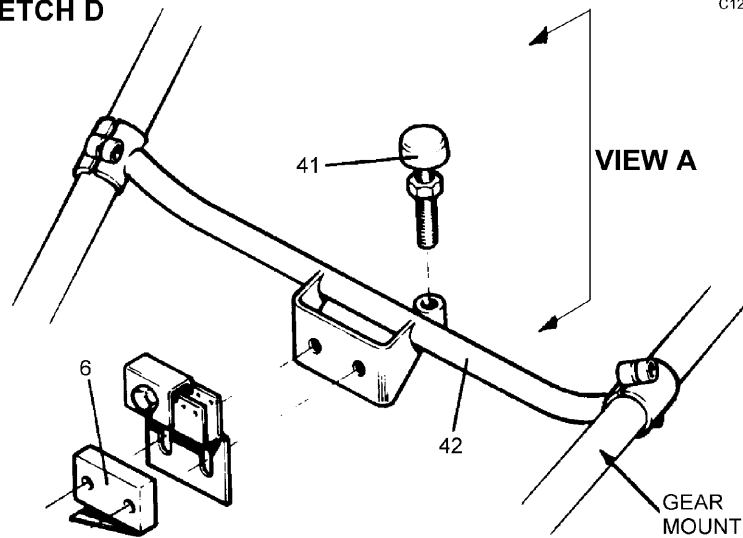

C122

RIGGING
DIMENSION

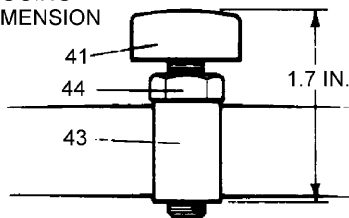

VIEW A

NOTE: Upstop NOT installed on PA-34-200 aircraft S/N 34-7250001 through 34-7350135 unless Kit 760-699 has been complied with.

Figure 3A
Nose Gear Installation

INSTRUCTIONS: (Continued)

4. Rigging Instructions

These Rigging Instructions are in effect until the contents of this service bulletin are incorporated into the appropriate Maintenance Manuals.

All other rigging instructions as called out in the "Installation and Rigging of the Nose Gear" section of the appropriate Aircraft Maintenance Manual are still valid and must be complied with in addition to these corrections/clarifications.

4.1 Nose Gear Drag Link Inspection and Adjustment

- a. For Senecas serial numbers 34-7250001 through 34-7450220: Rigging of the nose gear installation (Item 13, Table 1) shall be accomplished per this Service Bulletin. The 'over center' measurement for the Seneca, as for all Senecas, shall be 0.250 or greater as measured from the center (See Figure 3). The Service Manual will be revised to delete reference to Service Bulletin 413. All required measurements are in this service bulletin and will be incorporated into the Service Manual.
- b. For Senecas II through V: Rigging of the nose gear installation (Item 13, Table 1) shall be accomplished per the appropriate Service Manual with the following exception for the Seneca II. The 'over center' measurement for the Seneca II, as for all Senecas, shall be 0.250 or greater as measured from the center (See Figure 3). The 0.250 dimension supersedes the 0.300 dimension which was incorrectly stated in the Seneca II Maintenance Manual. Refer to the Maintenance Manual for the procedure to make the over center measurement. This Service Bulletin supersedes Service Bulletin No. 413, Nose gear Drag Link Dimension Check.

4.2 Steering Arm Channel Clearance

- a. Turn the nose gear full travel and make sure the clearance between the steering arm assembly and the tiller track is a minimum 0.03 of an inch at both the left and right stops. (see Figure 4). If insufficient clearance is obtained, loosen the upper mounting bolts for the tiller track and move the track upwards in the slotted holes where the track is attached to the gear mount assembly. Adjust to obtain a minimum clearance of 0.03 of an inch. Tighten the upper mounting bolts.

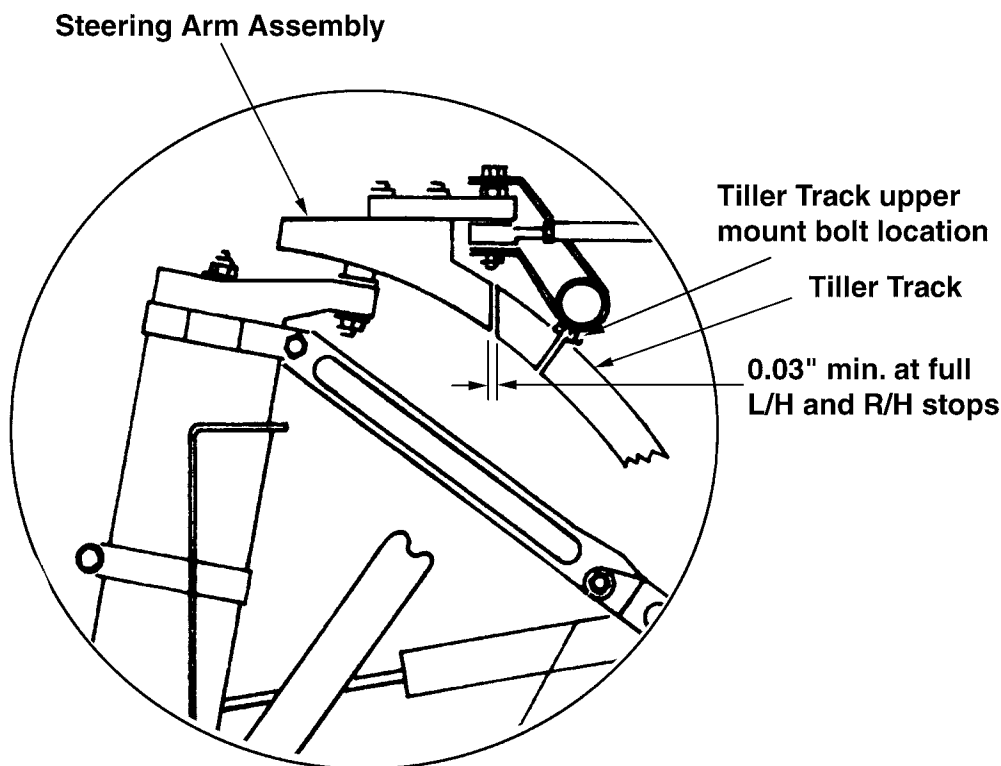

Figure 4
Steering Arm Channel Clearance

INSTRUCTIONS: (Continued)

4.3 Installation and Rigging of Nose Gear (Refer to Figures 3 and 3A)

NOTE: Installation and rigging instructions for the Seneca II aircraft will be revised to match the rigging instructions for the later Seneca models as follows.

NOTE: With reference to Chapter 12 for proper lubricants, ensure affected parts of the landing gear such as bearings, bushings, etc, are lubricated prior to and following assembly.

- a. Position the gear assembly between the mounting points, making certain the tiller roller is properly inserted in the steering arm channel.
- b. Align the mounting points of the strut with those on the mount and install the appropriate hardware. The bolt heads should be inboard, with the nuts outboard and just loose enough to allow the gear to swing freely.
- c. If necessary, assemble the drag links. Installed or removed, use the appropriate instructions in this section to check their rigging.
- d. The drag links are installed with their through center stops facing up, the upper link connection aligned with the right side of the gear's upper ring block and the lower link connection positioned in its bracket on the bottom rear of the nose gear mount (refer to Figure 3). With the links in position, install the connecting hardware and move the gear to assure free movement.
- e. At the actuator housing attachment assembly (see Sketch B, Figure 3A), disconnect the retention spring from the retraction link fitting.
- f. Position the gear in its down locked position and check that the drag links have fully extended to their through center position with the stop surfaces in contact.
- g. With the actuating piston rod extended, adjust the piston rod end such that 0.25 of an inch of rod travel remains in the actuator before full extension. Connect the rod end to its mount on the gear assembly. The retraction link to which the actuator is attached should be near its stop.
- h. Reconnect the retention spring to the retraction link fitting.
- i. Install the down lock link (see Figure 3) with the rod end connected to the retraction link and the other end to the bottom drag link.
- j. Adjust the down lock link as necessary until the guide pin is completely bottomed out at the top of its slot and the retraction link is moved against its stop.

NOTE: If the down lock link is adjusted properly, the retraction link will be moved completely to its stop by the down lock link therefore taking up some of the extra actuator piston rod travel and activating the down and locked limit switch.

- k. Retract and free fall the landing gear at least three times. Remove the down lock link, shorten it by 1/2 turn and reinstall.
- l. The down and locked limit switch should be adjusted to have it actuated when the retraction link is back against its stop.
- m. Using a tow bar to reach full travel against stops, rig the nose gear steering rod ends as necessary to allow full deflection.
- n. Refer to Figure 3A, Sketch D and set the up stop to the dimension shown. Retract the gear and ensure the nose gear housing engages the stop under retraction pressure. Adjust as necessary.

NOTE: After any up stop adjustment, the gear must be cycled to ensure the strut engages the stop under pressure.

INSTRUCTIONS: (Continued)

NOTE: For PA-34-200 aircraft (S/N 34-7250001 through 34-7350135) which do not have "Upstop" kit 760-699 installed, rig the up limit switch as noted:

All adjustments of the limit switches should be made with the airplane on jacks. Do not bend actuator springs mounted on the limit switches.

Adjustment of the nose gear up limit switch:

The gear up limit switch is mounted on a bracket attached to the lower inner left tubular member of the nose gear mount, adjacent to the gear roller track assembly.

To facilitate adjustment of the limit switch, disconnect gear doors.

Turn master switch ON, move gear selector switch to the gear up position and raise the landing gear. Turn the master switch OFF.

Block the nose gear in the up position and slowly pull the free fall knob away from the instrument panel. This will relieve hydraulic pressure and permit the main gear to drop.

Loosen the attachment screws of the switch and rotate the switch toward the actuator tang until the switch is heard to actuate. Retighten the switch attachment screws. Remove the block from under the gear and allow it to extend slowly.

Turn master switch on, raise gear and determine that the gear lights function properly.

- o. Retract the gear and check that the up switch is just activated when the gear contacts the stop. Following this, adjust the switch upward another 0.02 to 0.04 of an inch.
- p. Support the gear in its up locked position and adjust the rod end of the actuator piston rod to allow a minimum of 0.06 of an inch actuator travel remaining with the gear up and locked.
- q. Cycle the gear a few times and check down lock, and up stop action, and switch activation. Include short pickup cycles which simulate gear sag pickup in flight. Leave gear up.
- r. Check up switch bracket override action to ensure proper activation.
- s. Extend the gear and check that the actuator piston travel remaining till full extension is not less than .15 of an inch.
- t. Retract and free fall the gear to ensure the retraction link retention spring moves to the assemblies aft causing the down lock link to fully compress and the drag links to lock in their over center position.
- u. Turn the nose gear full travel and make sure the clearance between the steering arm assembly and the tiller track is between 0.06 and 0.03 of an inch at both the left and right stops.

CAUTION: THE TILLER, TILLER ROLLER, AND STEERING ARM CHANNEL CAN BE DAMAGED IF NOSE WHEEL TURN LIMITS ARE EXCEEDED WHEN TOWING THE AIRPLANE WITH POWER EQUIPMENT. INSPECT, ADJUST, REPAIR OR REPLACE AS REQUIRED.

- v. Verify free and correct movement of the tiller roller between the steering arm channel and the tiller track and up and down the tiller track.
- w. Refer to the appropriate paragraph in this section for rigging of the nose gear doors.
- x. Lube the system as specified in Chapter 12.
- y. Ascertain the gear is down and locked and check alignment of landing gear. Refer to the appropriate section of this chapter.
- z. Remove airplane from jacks.

MATERIAL REQUIRED: One (1) each, Nose Gear Hydraulic Jack Mount Assembly Kit, Piper part number 767-357; 767-358 or 767-359 (See Table 1 for correlation between the aircraft serial number effectivity and the correct Kit number required), Turn Limit Kit, Piper part number 767-368, NAS6207-50D bolt, Piper part number 693-215, Steering Channel, New Piper part number 95394-005, *if required*, per aircraft.

AVAILABILITY OF PARTS: Your Piper Field Service Facility.

EFFECTIVITY DATE: This Service Bulletin is effective upon receipt.

SUMMARY: Warranty is not available for this Service Bulletin. The kits available through this Service Bulletin are considered 'product improvements'.

Please contact your Factory Authorized Piper Service Facility to make arrangements for compliance with this Service Bulletin in accordance with the compliance time indicated.

NOTE: If you are no longer in possession of this aircraft, please forward this information to the present owner/operator and notify the factory of address/ownership corrections. Changes should include aircraft model, serial number, current owner's name and address.

Corrections/changes should be directed to:

THE NEW PIPER AIRCRAFT, INC.
Attn: Customer Service
2926 Piper Drive
Vero Beach, FL 32960